



PRECISION GEARHEADS



ISLAND COMPONENTS GROUP, INC.

PRECISION GEARHEADS

PRECISION GEARHEAD SIZE 8

GHA Series

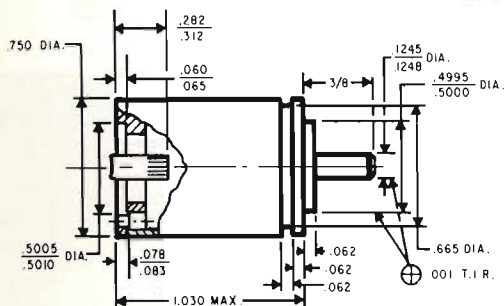

INPUT
END



.070 DIA. THRU 8 C' BORE
.093 / .096 DIA. OPPOSITE
SIDE. 3 HOLES EQUALLY
SPACED ON .589 ± .003 DIA

OUTPUT
END

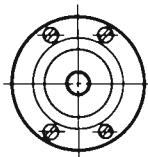

TYPE NO.	RATIO	ROTATION	BACKLASH (MAXIMUM)
GHA-005	7.79	Direct	45'
GHA-006	10.90	Reverse	45'
GHA-007	12.53	"	45'
GHA-008	14.46	"	45'
GHA-009	16.80	"	45'
GHA-010	19.70	"	45'
GHA-011	23.36	"	45'
GHA-012	28.15	"	45'
GHA-013	39.41	Direct	45'
GHA-014	45.29	"	45'
GHA-015	52.28	"	45'
GHA-016	60.75	"	45'
GHA-017	71.21	"	45'
GHA-018	84.46	"	45'
GHA-019	101.78	"	45'
GHA-020	142.50	Reverse	30'
GHA-021	163.74	"	30'
GHA-022	189.03	"	30'
GHA-023	219.64	"	30'
GHA-024	257.45	"	30'
GHA-025	305.35	"	30'
GHA-026	367.99	"	30'
GHA-027	515.18	Direct	30'
GHA-028	591.98	"	30'
GHA-029	683.40	"	30'
GHA-030	794.08	"	30'
GHA-031	930.79	"	30'
GHA-032	1103.96	"	30'
GHA-033	1330.42	"	30'
GHA-034	1862.58	Reverse	30'
GHA-035	2140.23	"	30'
GHA-036	2470.77	"	30'
GHA-037	2870.90	"	30'
GHA-038	3365.17	"	30'
GHA-039	3991.25	"	30'
GHA-040	4809.96	"	30'

PRECISION GEARHEAD SIZE 10

GHF Series

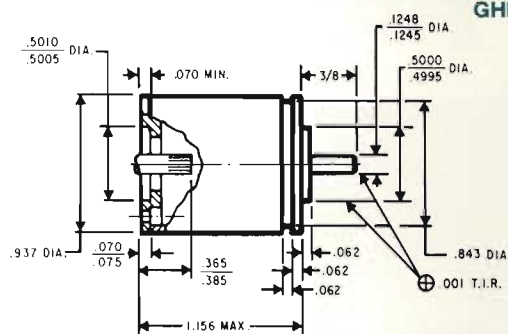

INPUT
END

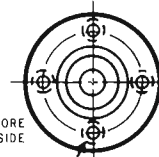

.081 DIA. THRU 8 C' BORE
.140 DIA. OPPOSITE SIDE
4 HOLES EQUALLY
SPACED ON .700 DIA. B.C

OUTPUT
END

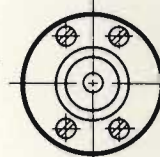

TYPE NO.	RATIO	ROTATION	BACKLASH (MAXIMUM)
GHF-005	10.23	Direct	45'
GHF-006	12.56	Reverse	45'
GHF-007	14.83	"	45'
GHF-008	17.62	"	45'
GHF-009	21.10	"	45'
GHF-010	25.58	"	45'
GHF-011	30.70	"	45'
GHF-012	39.99	"	45'
GHF-013	47.71	Direct	45'
GHF-014	56.37	"	45'
GHF-015	66.95	"	45'
GHF-016	80.18	"	45'
GHF-017	97.19	"	45'
GHF-018	116.63	"	45'
GHF-019	151.95	"	45'
GHF-020	181.31	Reverse	30'
GHF-021	214.21	"	30'
GHF-022	254.43	"	30'
GHF-023	304.70	"	30'
GHF-024	369.33	"	30'
GHF-025	443.20	"	30'
GHF-026	577.42	"	30'
GHF-027	688.97	Direct	30'
GHF-028	814.00	"	30'
GHF-029	966.83	"	30'
GHF-030	1157.85	"	30'
GHF-031	1403.47	"	30'
GHF-032	1684.15	"	30'
GHF-033	2194.20	"	30'
GHF-034	2618.08	Reverse	30'
GHF-035	3093.22	"	30'
GHF-036	3673.94	"	30'
GHF-037	4399.84	"	30'
GHF-038	5333.14	"	30'
GHF-039	6237.63	"	30'
GHF-040	8337.98	"	30'

SPEED REDUCER SIZE 8

SRA Series

The above ratio chart is also used to determine the figures necessary for ordering ISLAND COMPONENTS GROUP, Inc. Speed Reducers. Simply change the type number from GHA to SRA when ordering. Mechanical specifications and technical data available upon request.

SPEED REDUCER SIZE 10

SRF Series

The above ratio chart is also used to determine the figures necessary for ordering ISLAND COMPONENTS GROUP, Inc. Speed Reducers. Simply change the type number from GHF to SRF when ordering. Mechanical specifications and technical data available upon request.

PRECISION GEARHEAD SIZE 11

GHB Series

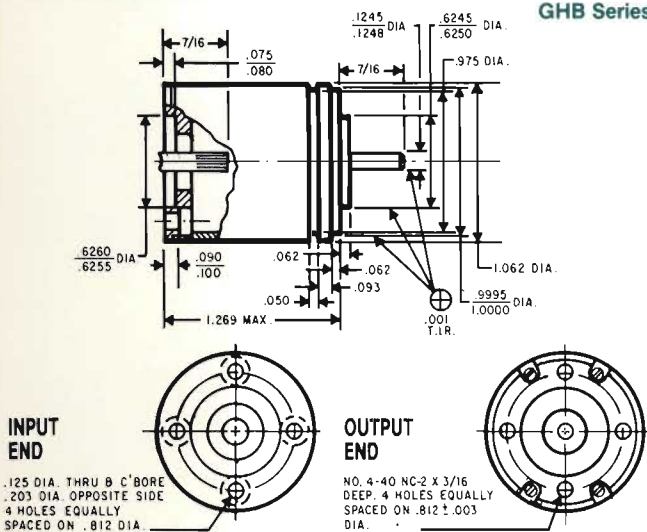

PRECISION GEARHEAD SIZE 15

GHC Series

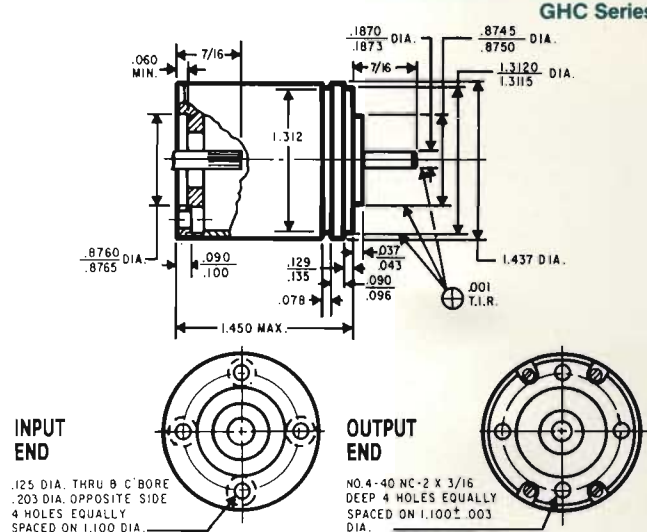

TYPE NO.	RATIO	ROTATION	BACKLASH (MAXIMUM)
GHB-008	14.77	Direct	45'
GHB-009	20.25	Reverse	45'
GHB-010	23.26	"	45'
GHB-011	26.86	"	45'
GHB-012	31.21	"	45'
GHB-013	36.58	"	45'
GHB-014	43.38	"	45'
GHB-015	56.62	"	45'
GHB-016	80.98	Direct	30'
GHB-017	93.06	"	30'
GHB-018	107.43	"	30'
GHB-019	124.83	"	30'
GHB-020	146.32	"	30'
GHB-021	173.54	"	30'
GHB-022	226.46	"	30'
GHB-023	323.94	Reverse	30'
GHB-024	372.23	"	30'
GHB-025	429.71	"	30'
GHB-026	499.30	"	30'
GHB-027	585.27	"	30'
GHB-028	694.15	"	30'
GHB-029	905.85	"	30'
GHB-030	1295.75	Direct	30'
GHB-031	1488.91	"	30'
GHB-032	1718.86	"	30'
GHB-033	1997.21	"	30'
GHB-034	2341.07	"	30'
GHB-035	2776.62	"	30'
GHB-036	3623.38	"	30'
GHB-037	5183.01	Reverse	30'
GHB-038	5955.64	"	30'
GHB-039	6875.43	"	30'
GHB-040	7988.86	"	30'
GHB-041	9364.27	"	30'
GHB-042	11106.46	"	30'
GHB-043	14493.54	"	30'

TYPE NO.	RATIO	ROTATION	BACKLASH (MAXIMUM)
GHC-005	11.73	Direct	45'
GHC-006	14.76	Reverse	30'
GHC-007	16.90	"	30'
GHC-008	19.39	"	30'
GHC-009	22.35	"	30'
GHC-010	25.94	"	30'
GHC-011	30.37	"	30'
GHC-012	35.98	"	30'
GHC-013	46.93	"	30'
GHC-014	59.01	Direct	30'
GHC-015	67.94	"	30'
GHC-016	77.54	"	30'
GHC-017	89.40	"	30'
GHC-018	103.75	"	30'
GHC-019	121.47	"	30'
GHC-020	143.93	"	30'
GHC-021	187.73	"	30'
GHC-022	236.40	Reverse	30'
GHC-023	270.34	"	30'
GHC-024	310.17	"	30'
GHC-025	357.59	"	30'
GHC-026	414.99	"	30'
GHC-027	485.90	"	30'
GHC-028	575.72	"	30'
GHC-029	750.93	"	30'
GHC-030	945.62	Direct	30'
GHC-031	1081.34	"	30'
GHC-032	1240.67	"	30'
GHC-033	1430.35	"	30'
GHC-034	1659.96	"	30'
GHC-035	1943.59	"	30'
GHC-036	2302.86	"	30'
GHC-037	3003.73	"	30'
GHC-038	3782.48	Reverse	30'
GHC-039	4325.38	"	30'
GHC-040	4962.69	"	30'
GHC-041	5721.40	"	30'
GHC-042	6639.83	"	30'
GHC-043	7774.37	"	30'
GHC-044	9211.45	"	30'
GHC-045	12014.93	"	30'

SPEED REDUCER SIZE 11

SRB Series

The above ratio chart is also used to determine the figures necessary for ordering ISLAND COMPONENTS GROUP, Inc. Speed Reducers. Simply change the type number from GHB to SRB when ordering. Mechanical specifications and technical data available upon request.

SPEED REDUCER SIZE 15

SRC Series

The above ratio chart is also used to determine the figures necessary for ordering ISLAND COMPONENTS GROUP, Inc. Speed Reducers. Simply change the type number from GHC to SRC when ordering. Mechanical specifications and technical data available upon request.

PRECISION GEARHEAD SIZE 18

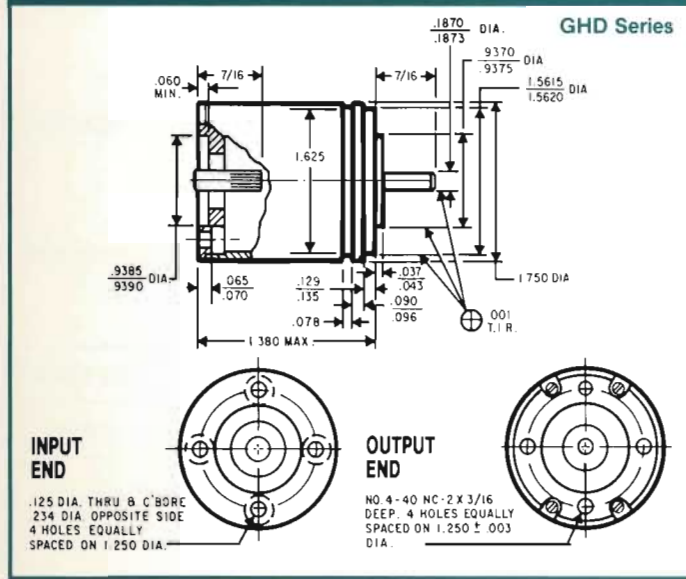

TYPE NO.	RATIO	ROTATION	BACKLASH (MAXIMUM)
GHD-005	17.07	Direct	45'
GHD-006	21.49	Reverse	30'
GHD-007	24.58	"	30'
GHD-008	28.20	"	30'
GHD-009	32.51	"	30'
GHD-010	37.73	"	30'
GHD-011	44.17	"	30'
GHD-012	52.34	"	30'
GHD-013	68.27	"	30'
GHD-014	85.97	Direct	30'
GHD-015	98.30	"	30'
GHD-016	112.79	"	30'
GHD-017	130.03	"	30'
GHD-018	150.91	"	30'
GHD-019	176.69	"	30'
GHD-020	209.35	"	30'
GHD-021	273.07	"	30'
GHD-022	343.86	Reverse	30'
GHD-023	393.22	"	30'
GHD-024	451.15	"	30'
GHD-025	520.13	"	30'
GHD-026	603.62	"	30'
GHD-027	706.76	"	30'
GHD-028	837.40	"	30'
GHD-029	1092.27	"	30'
GHD-030	1375.45	Direct	30'
GHD-031	1572.86	"	30'
GHD-032	1804.61	"	30'
GHD-033	2080.51	"	30'
GHD-034	2414.48	"	30'
GHD-035	2827.04	"	30'
GHD-036	3349.62	"	30'
GHD-037	4369.07	"	30'
GHD-038	5501.79	Reverse	30'
GHD-039	6291.46	"	30'
GHD-040	7218.46	"	30'
GHD-041	8322.03	"	30'
GHD-042	9657.94	"	30'
GHD-043	11308.17	"	30'
GHD-044	13398.47	"	30'
GHD-045	17476.27	"	30'

SPEED REDUCER SIZE 18

SRD Series

The above ratio chart is also used to determine the figures necessary for ordering ISLAND COMPONENTS GROUP, Inc. Speed Reducers. Simply change the type number from GHD to SRD when ordering. Mechanical specifications and technical data available upon request.

PLANETARY GEARHEAD

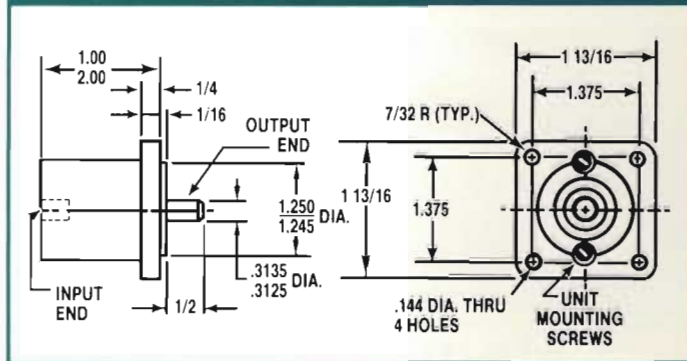

Optional .25 diameter output shaft is available, except maximum torque load is reduced to 500 oz-in continuous duty.

For motor mounting configuration on input end, consult our Engineering Department.

All gears are heat treated for reliable performance and long life.

Backlash varies with reduction ratio, but the average unit will be less than 3°.

The life of the gearheads shall be 200 to 5000 hours of continuous duty depending upon the gearhead ratio, temperature and method it is being driven. Any of our motors can be combined with any gearhead as a Motor Gearhead Combination (see Motors catalog).

Mechanical configuration is provided for one gearhead as an example. For variations in performance (ie; mounting arrangements, length, etc.) consult our Engineering Department.

Planetary Gearheads Even Ratios & Performance

SPEED REDUCTION RATIO	TORQUE MULTIPLIER	GEAR-TRAIN MAX. CONT. RATING (oz-in)	GEAR-TRAIN EFFICIENCY (%)	SPEED REDUCTION RATIO	TORQUE MULTIPLIER	GEAR-TRAIN MAX. CONT. RATING (oz-in)	GEAR-TRAIN EFFICIENCY (%)
4:1	3.0	5.1	75	1600:1	522	887	33
5:1	3.8	6.5	75	1920:1	625	1063	33
6:1	4.5	7.7	75	2000:1	652	1108	33
16:1	10	17	63	2304:1	750	1250	33
20:1	13	22	63	2400:1	780	1250	33
24:1	15	26	63	2500:1	815	1250	33
25:1	16	27	63	2880:1	940	1250	33
30:1	19	32	63	3000:1	980	1250	33
36:1	23	39	63	3125:1	1020	1250	33
64:1	33	56	52	3456:1	1130	1250	33
80:1	41	70	52	3600:1	1170	1250	33
96:1	49	83	52	3750:1	1220	1250	33
100:1	51	87	52	4096:1	1070	1250	26
120:1	61	104	52	4320:1	1410	1250	33
125:1	64	109	51	4500:1	1470	1250	33
144:1	74	126	51	5120:1	1340	1250	26
150:1	77	131	51	5184:1	1690	1250	33
180:1	92	156	51	5400:1	1760	1250	33
216:1	110	187	51	6144:1	1610	1250	26
256:1	105	179	41	6400:1	1680	1250	26
320:1	130	221	41	6480:1	2110	1250	33
384:1	157	267	41	7680:1	2010	1250	26
400:1	164	279	41	7776:1	2530	1250	33
480:1	197	335	41	8000:1	2100	1250	26
500:1	205	349	41	9216:1	2390	1250	26
576:1	236	401	41	9600:1	2520	1250	26
600:1	246	418	41	10,000:1	2620	1250	26
625:1	256	435	41	11,520:1	3010	1250	26
720:1	295	502	41	12,000:1	3140	1250	26
750:1	306	520	41	12,500:1	3280	1250	26
864:1	352	598	41	13,824:1	3620	1250	26
900:1	370	629	41	14,400:1	3780	1250	26
1024:1	334	568	33	15,000:1	3940	1250	26
1080:1	442	751	41	15,625:1	4100	1250	26
1280:1	416	707	33	17,280:1	4520	1250	26
1296:1	530	901	41	18,000:1	4710	1250	26
1536:1	500	850	33	18,750:1	4910	1250	26

ODD RATIO PERFORMANCE DATA AVAILABLE UPON REQUEST

GEARHEADS



SPUR

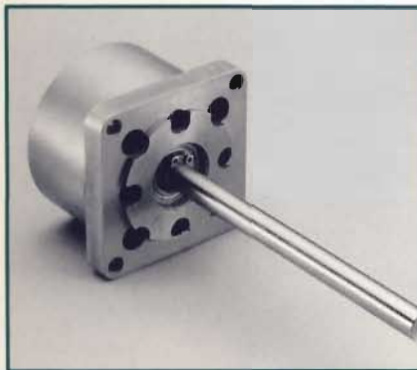

PLANETARY

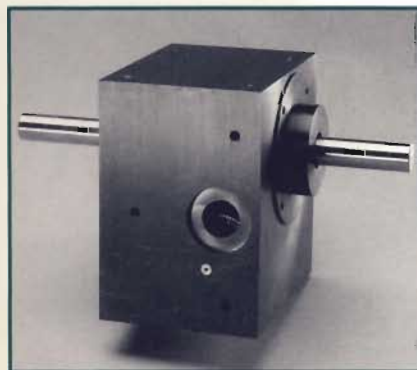

WORM



BEVEL

GEARHEADS & SPEED REDUCERS

General Mechanical Specifications

- Shaft end play shall be .004" maximum with a one pound gage load.
- Shaft radial play shall be .002" maximum per inch length with a 4 ounce gage load.
- Bearings are stainless steel ball bearings lubricated for -55°C to +125°C temperature.
- Material shall be stainless steel throughout except black anodized aluminum housing and adapter.

	GHA SERIES	GHB SERIES	GHC SERIES	GHD SERIES	GHF SERIES	
BACKLASH REVERSING LOAD	1 oz-in	3 oz-in	5 oz-in	10 oz-in	2 oz-in	
MAXIMUM INPUT SHAFT STARTING TORQUE	.005 oz-in	.005 oz-in	.008 oz-in	.01 oz-in	.005 oz-in	
MAXIMUM INPUT SHAFT OPERATING LOAD TORQUE	5 oz-in	25 oz-in	35 oz-in	60 oz-in	10 oz-in	
MOMENTARY OUTPUT SHAFT LOAD TORQUE	30 oz-in	100 oz-in	100 oz-in	165 oz-in	50 oz-in	
MAXIMUM MOMENT OF INERTIA AT INPUT SHAFT	.0012 gm-cm ²	.02 gm-cm ²	.04 gm-cm ²	.15 gm-cm ²	.003 gm-cm ²	
MOTOR PINION	# OF TEETH	13	13	15	15	13
	DIMETRAL PITCH	120	120	96	96	120
	PRESSURE ANGLE	20°	20°	20°	20°	20°
	PITCH DIAMETER	.1083/.1078	.1083/.1078	.1562/.1557	.1562/.1557	.1083/.1078
	OUTSIDE DIAMETER	.1247/.1242	.1247/.1242	.1771/.1766	.1771/.1766	.1247/.1242

QUALITY CONTROL

Assuring Reliability and Dependability

- ISLAND'S strict quality control inspection and testing procedures assure that all components and completed products conform to the requirements requested by the customer. Each part must meet the highest standards for safety, workmanship, and functional capabilities before they leave our plant.
- A checklist including stages of inspection, from receipt, to manufacturing, to final shipment, documents product analysis and test reports. This eliminates any sub-standard qualities or defects that could affect performance and allows corrective action to be taken before you receive any components from ISLAND.
- All products manufactured at ISLAND are made per MIL-I-45208A Military Inspection systems. All ISLAND personnel are available to answer any product conformance questions or accuracy verification requests by governmental representatives.
- From time to time, ISLAND gets requests to engineer and manufacture components with "special custom capabilities" that enhance performance beyond Mil spec guidelines or requirements. Custom testing will then be conducted.

ISLAND COMPONENTS GROUP

Putting Your Ideas Into Motion

Engineering & Design Assistance

In today's modern world, every component manufactured must be designed to meet certain exact specifications. Having highly trained, qualified engineers on staff at all times is essential to achieve first rate results on each project. At ISLAND, when it comes to providing the expertise to get the job done, we wrote the book. Each engineering application provides us with a new challenge, whether it's enhanced performance, or trouble-shooting an intricate in-line assembly, we're ready. Talk to us about your next project or ideas and we'll get the gears into motion right away.

Special Applications

- Gear Ratios
- Bearing and Lubrication
- Temperature Range
- Mechanical Configurations (Shaft, Body Diameter or Length)
- Reduced Backlash
- Anti-Backlash Systems
- Slip Clutches
- Inline-Assemblies Can Be Designed to Special Requirements

Customer Service

From the moment you call, the friendly professionals at ISLAND are available to intelligently work with you.

It is important to us that you are kept informed of each job's status, from the moment you place an order, through manufacturing, to final on-time delivery.

Whatever your needs are, you'll receive the courteous service that's grown to be a trademark at ISLAND COMPONENTS GROUP, Inc.



MOTORS

BRUSHLESS MOTORS
STEPPER MOTORS
SERVOMOTORS
MOTOR GENERATORS
INERTIALLY DAMPED
HYSTERESIS
SYNCHRONOUS
TACHOMETERS
INTEGRATORS



GEARHEADS

PLANETARY
SPEED REDUCERS
SPUR GEARHEADS



BRAKES & CLUTCHES

ELECTROMAGNETIC
BRAKES
SPRING BRAKES
ELECTROMAGNETIC
CLUTCHES
SPRING CLUTCHES

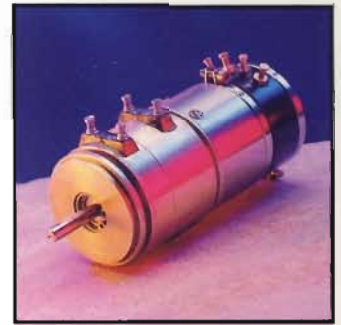

IN-LINE ASSEMBLIES

ACTUATORS
IN-LINE PACKAGES
STATORS
ROTORS
CUSTOM ASSEMBLIES
SPEED CONTROLS
SHAFT SPRING
RETURNS



ISLAND COMPONENTS GROUP, INC.

340-A Central Avenue, Bohemia, New York 11716

631.563.4224

Fax us at 631.563.4363 or get fast track design assistance on-line:

www.islandcomponents.com